

Datasheet

FS3871

LINEAR CHARGE MANAGEMENT IC FOR LITHIUM-ION AND LITHIUM-POLYMER

FORTUNE,
Properties,
For Reference Only

Fortune Semiconductor Corporation

富晶電子股份有限公司
23F., No.29-5, Sec. 2, Zhongzheng E. Rd.,
Danshui Sec., Taipei County 251, Taiwan
Tel. : 886-2-28094742
Fax : 886-2-28094874
www.ic-fortune.com

FORTUNE,
Properties
For Reference Only

This manual contains new product information. **Fortune Semiconductor Corporation** reserves the rights to modify the product specification without further notice. No liability is assumed by Fortune Semiconductor Corporation as a result of the use of this product. No rights under any patent accompany the sale of the product.

1. General Description

The FS3871 Lithium-Ion (Li-Ion) and Lithium-Polymer (Li-Pol) linear charge-management ICs are designed for cost sensitive and compact portable electronics. They combine high-accuracy current and voltage regulation, battery conditioning, temperature monitoring, charge termination, charge-status indication, and Automatic charge-rate compensation in a single 8-pin IC. TSSOP package is offered to fit a wide range of end applications.

The FS3871 continuously measures battery temperature using an external thermistor. For safety, the FS3871 inhibits charge until the battery temperature is within user-defined thresholds. The FS3871 then charges the battery in three phases: conditioning, constant current and constant voltage. If the battery voltage is below the low-voltage threshold, $V(\min)$, the FS3871 pre-charges using a low current to condition the battery. The conditioning charge rate is approximately 10% of the regulation current. The conditioning current also minimizes heat dissipation in the external pass element during the initial stage of the charge. After conditioning, the FS3871 applies a constant current to the battery. An external sense-resistor sets the current. The sense-resistor can be on either the high or low side of the battery without additional components. The constant-current phase continues until the battery reaches the charge-regulation voltage.

The available 8-pin TSSOP-8 package is offered for balanced area and cost effective requirements for size-sensitive applications.

The FS3871 is suitable for the control of charge sequences of a variety of portable battery-powered applications, such as cellular phone's travel and base charger devices, digital camera, digital-video camcorder (DV), MP3 player ,etc.

2. Features

Ideal for Single (4.1 V or 4.2 V) and Dual-Cell (8.2 V or 8.4 V) Li-Ion or Li-Poly Packs. (Dual-Cell is not available now)

0.3 V dropout voltage for minimizing heat dissipation.

Better than $\pm 1\%$ voltage regulation accuracy with preset voltages.

Automatic Dynamic Compensation of battery pack's internal impedance to reduce charge time.

Optional cell-temperature monitoring before and during charge.

Integrated voltage and current regulation with programmable charge-current and high or low-side current sensing.

Integrated cell conditioning for reviving deeply discharged cells and minimizing heat dissipation during initial stage of charge.

Charge status output for single or dual LED or host processor interface.

Automatic battery-recharge feature.

Charge termination by minimum current.

Automatic low-power sleep mode when VCC is removed.

Low-cost peripheral components of capacitor and resistor combinations for minimum BOM cost in manufacturing considerations.

Evaluation (EV) board is available for quick evaluation.

TSSOP-8 Green Package.

3. Applications

Cellular phone external base or built-in charger

MP3/MP4 player

External charger through USB

Digital still camera (DSC)

Digital video camcorder (DV)

Portable electronic device charger, etc.

4. Pin Configuration

(TSSOP-8 TOP VIEW)

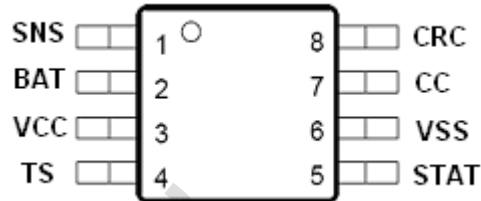

5. Ordering Information

Product Number	Description	Package Type
FS3871D-G	CHARGE REGULATION VOLTAGE : 4.2V	TSSOP-8

6. Pin Description

Name	I/O	Pin No.	Description
SNS	I	1	Current sense input
BAT	I	2	Voltage sense input
VCC	I	3	Supply voltage
TS	I	4	Temperature sense input
STAT	I/O	5	Charge status output
VSS	-	6	Ground
CC	O	7	Charge control output
CRC	I	8	Charge-rate compensation input

7. Pin Description Package Marking Information

Part Number	Package Type	Marking
FS3871D-G	TSSOP-8	FS3871D *****

Top line: Part Number.
Bottom line : Lot No.

8. Functional Block Diagram

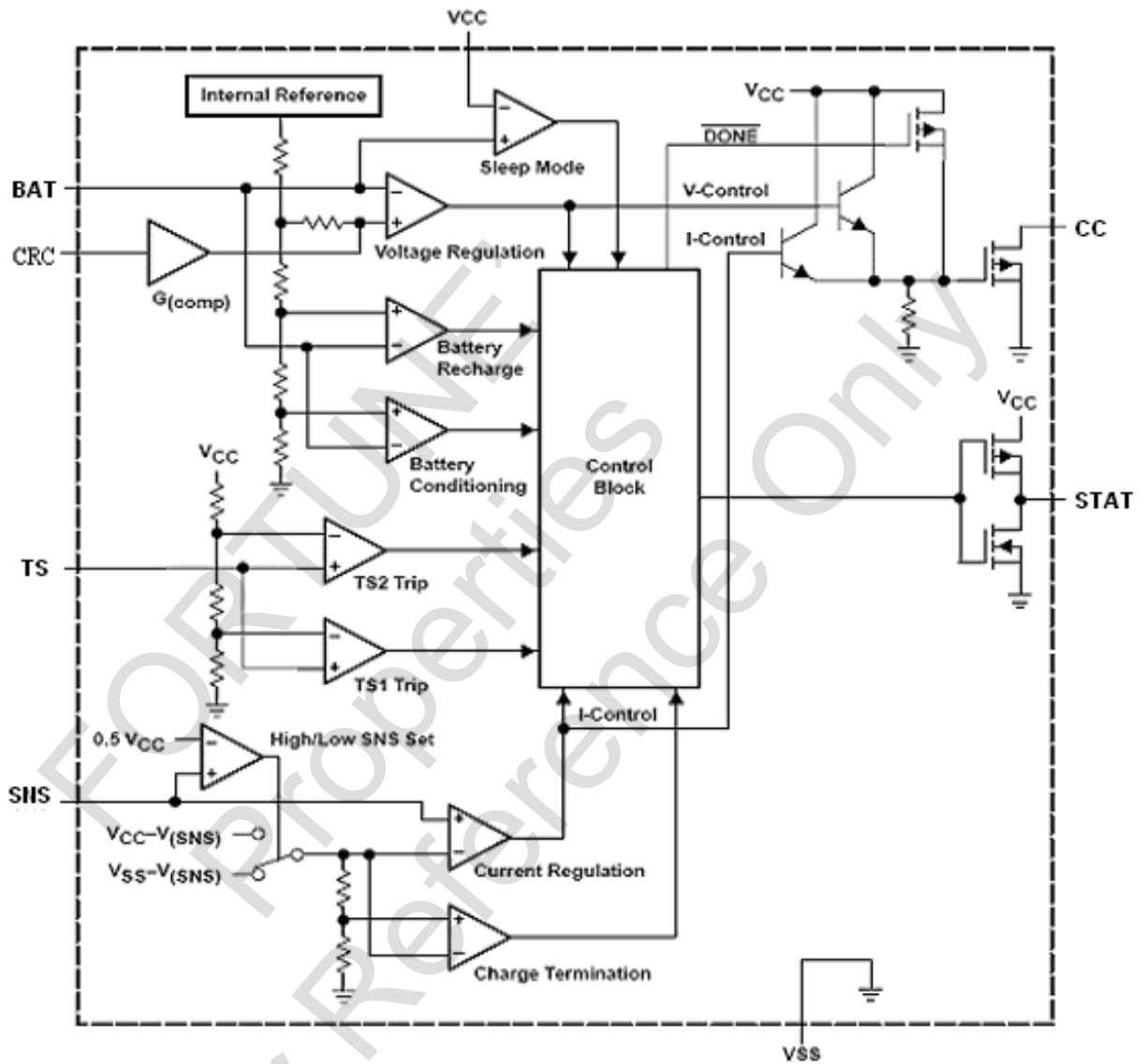

FS3871 Functional Block Diagram

9. Typical Application Circuit

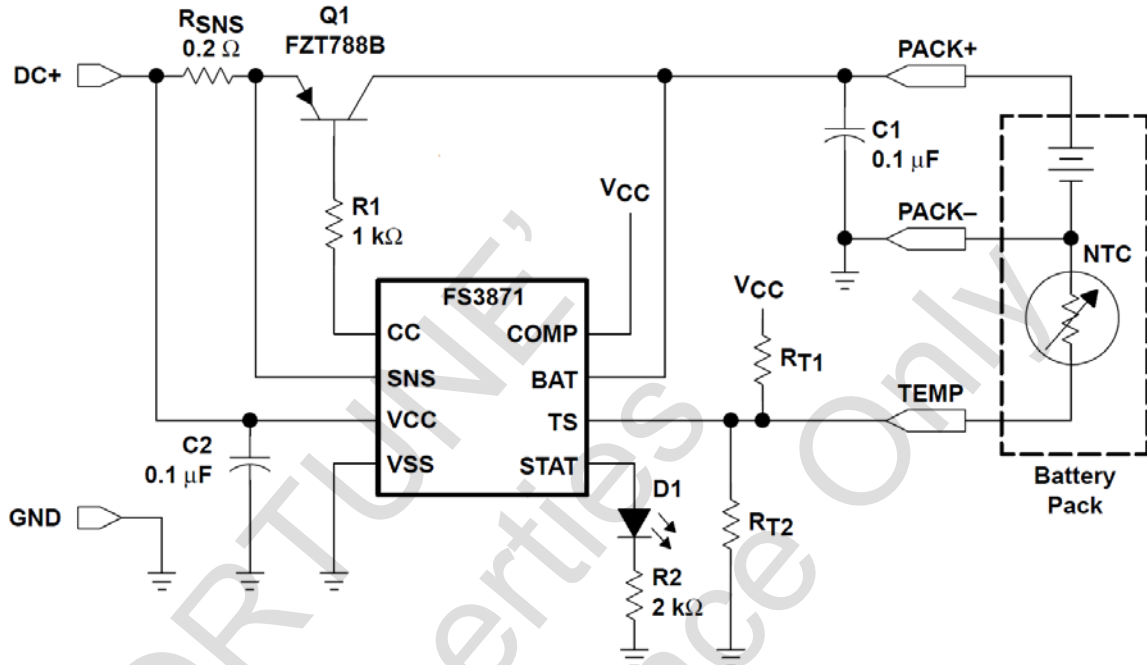

Figure 1. FS3871 Typical Application for one cell

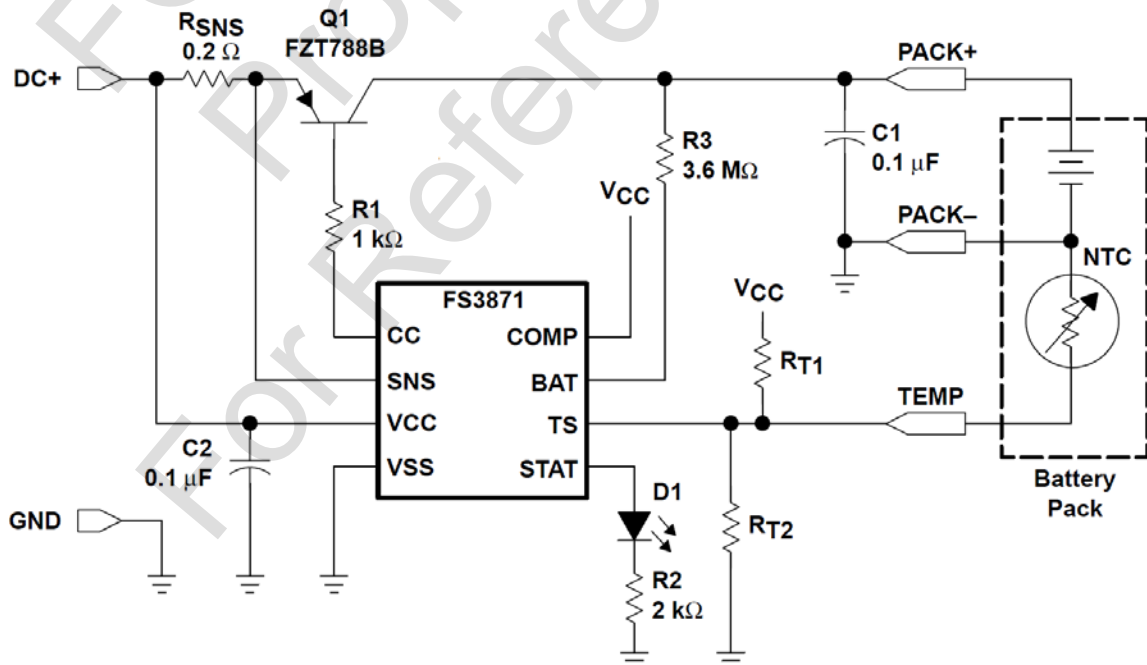

Figure 2. FS3871 Optional Application for one cell

Note: R3 3.6 MΩ can be added between PACK+ and BAT pin to prevent leakage current when VCC input is connected and VCC < 3.2V.

10. Charge profile

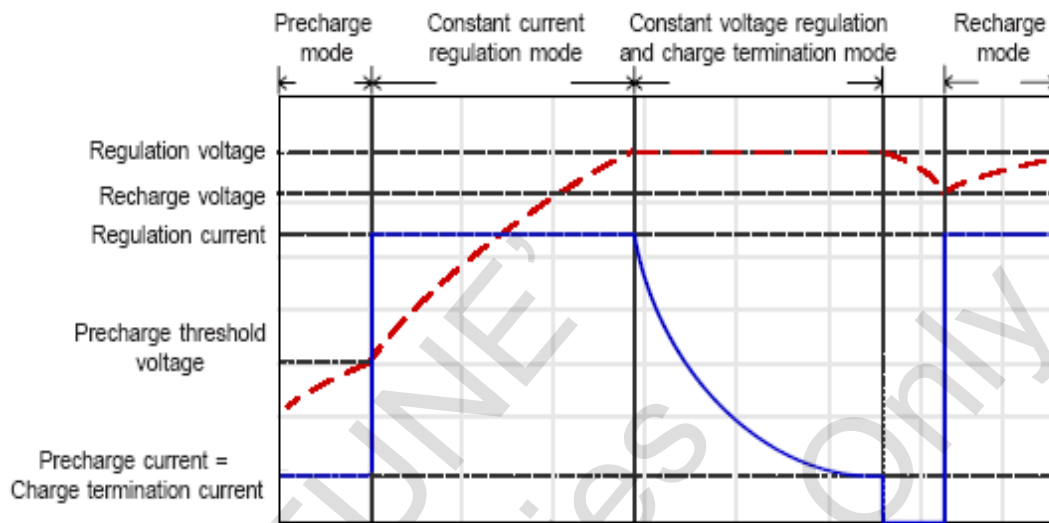

Figure 3.

11. Absolute Maximum Ratings

((unless otherwise noted))

Parameter	Rating	Unit
Supply voltage (Vcc with respect to GND)	-0.3 to 18	V
Input voltage, SNS, BAT, TS, CRC (all with respect to GND)	-0.3 to VCC+0.3	V
Sink current (STAT pin) not to exceed P _D	20	mA
Source current (STAT pin) not to exceed P _D	10	mA
Output current (CC pin) not to exceed P _D	40	mA
Total power dissipation, P _D (at 25°C)	300	mW
Operating free-air temperature range, T _A	-10 to 70	°C
Storage temperature range, T _{stg}	-40~125	°C
Lead temperature (soldering, 10 s)	300	°C

12. Electrical Characteristics

13. DC Characteristics

(TA=25°C, unless otherwise noted)

PARAMETER	TEST CONDITIONS	MIN	TYP	MAX	UNIT
VO(REG)	V(BAT)+0.3 V ≤ VCC ≤ VCC(max)	4.158	4.200	4.242	V
V(RCH)		VO(REG)-98 mV	VO(REG)-100 mV	VO(REG)-102 mV	v
V(min)		3.04	3.10	3.16	V
V(SNS)	High-side current sensing configuration	95.4	105	115.5	mV
	Low-side current sensing configuration	90	110	130	mV
V(TS1)	TS pin voltage	29.1	30.0	30.9	%V
V(TS2)	TS pin voltage	58.3	60.0	61.8	%V
G(CRC)	V(BAT)+0.3 V ≤ VCC ≤ VCC(max)	1.87	2.2	2.53	V/V
VOL(STAT)	IOL = 10mA			0.70	V
VOH(STAT)	IOH = 3mA	VCC-0.5			V
VOL(CC)	IO(CC) = 2 mA (sink)			1.5	V
I(VCC)	VCC > VCC(min), Excluding external loads		0.1	0.2	mA
IIB(BAT)	V(BAT) = V(REG)			2	uA
IIB(SNS)	V(SNS)= 5 V			2	uA
IIB(TS)	V(TS) = 5 V			2	uA
IIB(CRC)	V(CRC) = 5 V			2	uA
I(VCCS)	V(BAT) ≥ V(min), V(BAT) - VCC ≥ 0.8 V		0.5	2	μA
IO(CC)	Not to exceed power rating specification (PD)	5		40	mA
I(TERM)	Voltage at pin SNS, relative to VCC for high-side sensing, 0°C ≤ TA ≤ 50°C	-30	-14	-4	mV
I(PRECHG)	Voltage at pin SNS, relative to VCC for high-side sensing, 0°C ≤ TA ≤ 50°C, VCC = 5 V	3	13	22	mV

14. Typical Operating Characteristics

(Cin=0.1μF, Cout=4.7μF, TA=+25°C, unless otherwise noted.)

VO(REG) VS Temperature

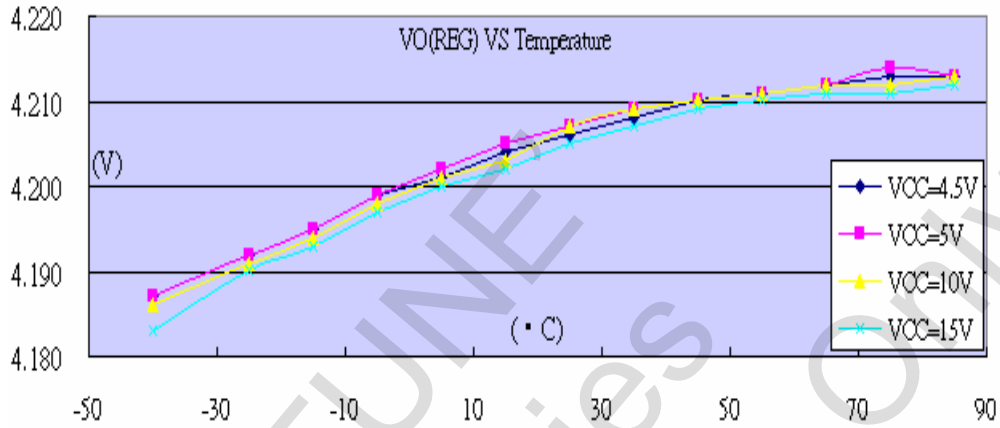

VRCH VS Temperature

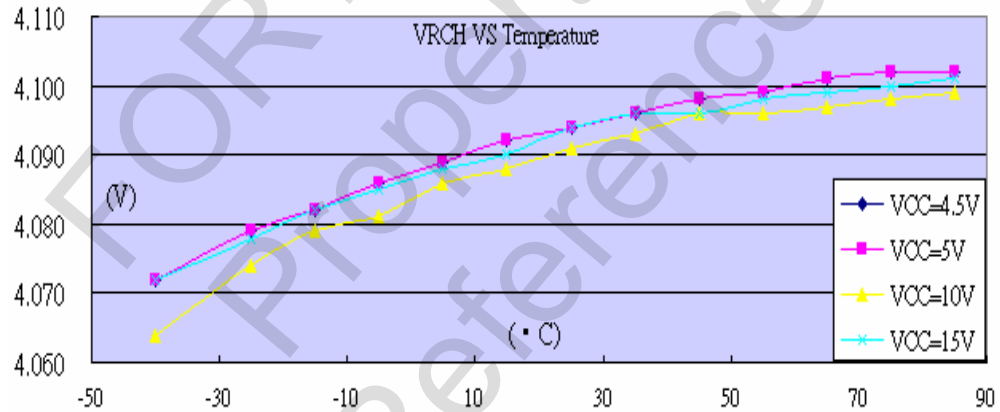

Vmin VS Temperature

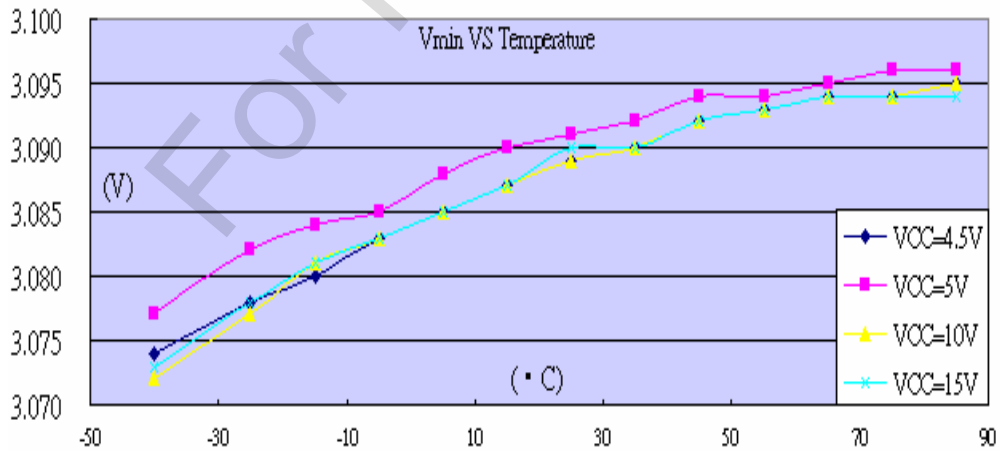

15. Detail Description

Precharge mode

FS3871's charge qualification is based on battery temperature and voltage. The FS3871 suspends charge if the battery temperature is outside the V(TS1) to V(TS2) range and suspends charge until the battery temperature is within the allowed range. The FS3871 also checks the battery voltage. If the battery voltage is below the precharge threshold V(min), the FS3871 uses precharge to condition the battery. The conditioning charge rate I(PRECHG) is set at approximately 10% of the regulation current. The conditioning current also minimizes heat dissipation in the external pass-element during the initial stage of charge. See Figure 3.

Sleep mode

The FS3871 enters the sleep mode if the VCC falls below the voltage at the BAT input. This feature prevents draining the battery pack during the absence of VCC.

Constant current regulation charge mode

The FS3871 regulates current while the battery-pack voltage is less than the regulation voltage, VO(REG). The FS3871 monitors charge current at the SNS input by the voltage drop across a sense-resistor, RSNS, in series with the battery pack. In high-side current sensing configuration (Figure 1), RSNS is between the VCC and SNS

The following formula calculates the value of the sense resistor:

$$R_{SNS} = \frac{V_{(SNS)}}{I_O (REG)}$$

Where IO(REG) is the desired charging current.

Charge termination and recharge

The FS3871 monitors the charging current during the voltage-regulation phase. The FS3871 declares a done condition and terminates charge when the current tapers off to the charge termination threshold, I(TERM). A new charge cycle begins when the battery voltage falls below the V(RCH) threshold.(See figure 3)

Battery temperature monitoring

The FS3871 continuously monitors temperature by measuring the voltage between the TS and VSS pins. A negative- or a positive-temperature coefficient thermistor (NTC, PTC) and an external voltage divider typically develop this voltage. (See Figure 1.) The FS3871 compares this voltage against its internal V(TS1) and V(TS2) thresholds to determine if charging is allowed. (See Figure 4.)

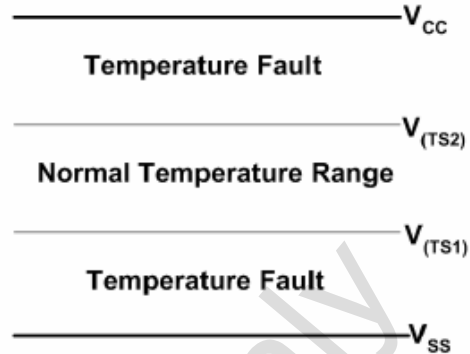

Figure 4. TS Input Thresholds

The temperature sensing circuit is immune to any fluctuation in VCC, since both the external voltage divider and the internal thresholds (V(TS1) and V(TS2)) are referenced to VCC. The resistor values of R(T1) and R(T2) are calculated by the following equations:

For NTC Thermistors:

$$R_{T1} = \frac{5 \times R_{TH} \times R_{TC}}{3 \times (R_{TC} - R_{TH})}$$

$$R_{T2} = \frac{5 \times R_{TH} \times R_{TC}}{[(2 \times R_{TC}) - (7 \times R_{TH})]}$$

For PTC Thermistors

$$R_{T1} = \frac{5 \times R_{TH} \times R_{TC}}{3 \times (R_{TH} - R_{TC})}$$

$$R_{T2} = \frac{5 \times R_{TH} \times R_{TC}}{[(2 \times R_{TH}) - (7 \times R_{TC})]}$$

Where R(TC) is the cold temperature resistance and R(TH) is the hot temperature resistance of thermistor, as specified by the thermistor manufacturer. RT1 or RT2 can be omitted if only one temperature (hot or cold) setting is required. Applying a voltage between the V(TS1) and V(TS2) thresholds to pin TS disables the temperature-sensing feature.

Charge status indication

The FS3871 indicates the status of the charger on the 3-state STAT pin. The following table shows the statuses of this pin .

Condition	STAT pin
Battery conditioning and charging	High
Charge complete(done)	Low
Temperature fault or sleep mode	Hi-Z

Voltage regulation phase

The voltage regulation feedback is through the BAT pin. This input is tied directly to the positive side of the battery pack. The FS3871 monitors the battery-pack voltage between the BAT and VSS pins.

The FS3871 is offered in two fixed-voltage versions: 4.2V and 8.4 V.

Other regulation voltages can be achieved by adding a voltage divider between the positive and negative terminals of the battery pack. The voltage divider presents scaled battery-pack voltage to BAT input.

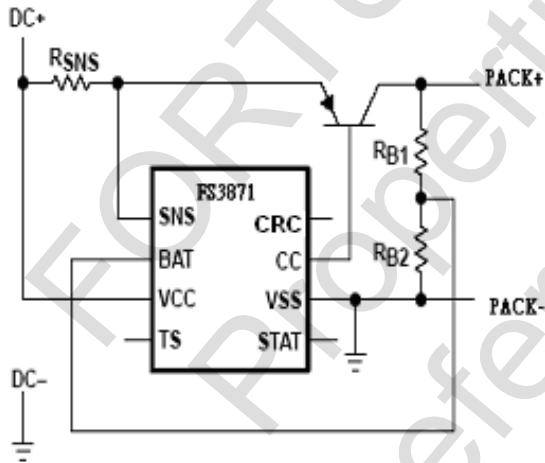

The resistor values RB1 and RB2 for the voltage divider are calculated by the following equation:

$$\frac{RB1}{RB2} = \left[N * \frac{V_{(CELL)}}{V_{O(REG)}} \right] - 1$$

Where:

N = Number of cells in series

V(CELL) = Desired regulation voltage per cell

Automatic charge-rate compensation

For internal impedance of the battery pack, the FS3871 uses the proprietary automatic charge-rate compensation technique (CRC).

The CRC pin must not be left floating. The feature is disabled by connecting the CRC pin to VCC in high-side current-sensing configuration, and to VSS in low-side current-sensing configuration.

Compensation is achieved through input pin CRC. A portion of the current-sense voltage, presented

through this pin, is scaled by a factor of G(CRC) and summed with the regulation threshold, VO(REG). This process increases the output voltage to compensate for the battery pack's internal impedance and for undesired voltage drops in the circuit.

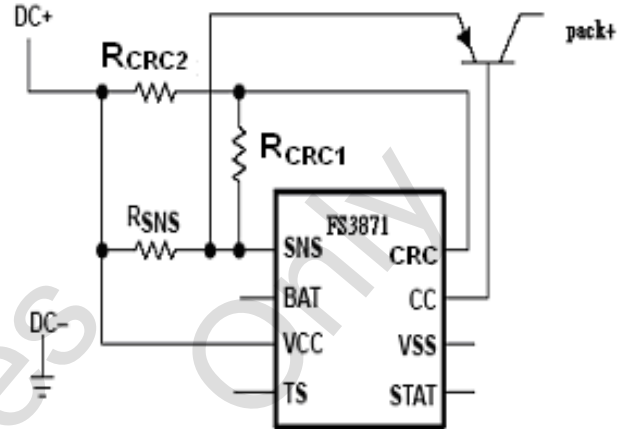

The CRC setup requires the following information:

1. Total impedance of battery pack (Z(PACK))
 2. Maximum charging current (I(REG))
- The voltage drop across the internal impedance of battery pack, V(Z), can then be calculated using the following equation:

$$V(Z) = Z(PACK) * I(REG)$$

$$V_{(CRC)} = \frac{V(Z)}{G_{(CRC)}}$$

$$V_{(PACK)} = V_{O(REG)} + [G_{(CRC)} * V_{(CRC)}]$$

Where V(CRC) is the voltage on CRC pin. This voltage is referenced to VCC in high-side current sensing configuration and to VSS for low-side sensing. V(PACK) is the voltage across the battery pack. The values of R(CRC1) and R(CRC2) can be calculated using the following equation:

$$\frac{V_{(CRC)}}{V_{(SNS)}} = \frac{R_{(CRC2)}}{R_{(CRC1)} + R_{(CRC2)}}$$

16. Application Information

Selecting an external pass-transistor

The FS3871 drives an external PNP transistor or P-channel MOSFET to control the charging current. The specifications must be concerned are the voltage and current rating and package power dissipation. The following examples illustrate the design process for either device:

PNP transistor:

Selection steps for a PNP bipolar transistor:
 Example: VI = 4.5 V, I(REG) = 1 A, 4.2-V single-cell Li-Ion .VI is the input voltage to the charger and I(REG) is the desired charge current (see Figure 1).

1. Determine the maximum power dissipation, PD, in the transistor.

The worst case power dissipation happens when the cell voltage, V(BAT), is at its lowest (typically 3 V at the beginning of current regulation phase) and VI is at its maximum. Where VCS is the voltage drop across the current sense resistor.

$$PD=(VI - VCS - VBAT) \times IREG$$

$$PD=(4.5 - 0.1 - 3.) \times 1A$$

$$PD=1.4W$$

2. Determine the package size needed in order to keep the junction temperature below the manufacturer's recommended value, T(J)max. Calculate the total theta, (□C/W), needed.

$$\theta_{JA} = \frac{T_{J(MAX)} - T_{A(MAX)}}{P_D}$$

$$\theta_{JA} = \frac{(150 - 40)}{1.4}$$

$$\theta_{JA} = 78^\circ C/W$$

Now choose a device package with a theta at least 10% below this value to account for additional thetas other than the device. A SOT223 package, for instance, has typically a theta of 60□C/W.

3. Select a collector-emitter voltage, V(CE), rating greater than the maximum input voltage. A 15-V device will be adequate in this example. Select a device that has at least 50% higher drain current IC rating than the desired charge current I(REG).

4. Using the following equation, calculate the minimum beta (β□or hFE) needed:

$$\beta_{min} = \frac{Ic(max)}{I_B}$$

where Ic(max) is the maximum collector current (in this case same as I(REG)), and IB is the base current.

Selecting input/output capacitor

In analog circuit applications, all that is needed is a high-frequency decoupling capacitor. A 0.1 uF ceramic, placed in proximity to VCC and VSS pins, works well. If a high ripple and noise input power is chosen, it should have enough capacitance to reduce the disturbance. A 0.1uF to 10uF output capacitor is recommended to control the output voltage and keep the output voltage ripple small when the battery is disconnected.

P-Channel MOSFET

Selection steps for a P-channel MOSFET: We will use the following conditions: VI=5V; I(REG)=1A, 4.2-V single-cell Li-Ion. VI is the input voltage to the charger and I(REG) is the desired charge current.

1. Determine the maximum power dissipation, PD, in the transistor. The worst case power dissipation happens when the cell voltage, V(constant), is at its lowest (typically 3.1V at the beginning of current regulation phase) and VI is at its maximum. Where VD is the forward voltage drop across the reverse-blocking diode (if one is used), and VCS is the voltage drop across the current sense resistor.

$$PD=(VI(MAX) - VD - VCS - VBAT) \times IREG$$

$$PD=(5.5 - 0.4 - 0.2 - 3.1) \times 1A$$

$$PD=1.8W$$

2. Determine the package size needed in order to keep the junction temperature below the manufacturer's recommended value, TJMAX. Calculate the total theta,θ(°C/W), needed. It is recommended to choose a package with a lower θJA than the number calculated above.

$$\theta_{JA} = \frac{T_{J(MAX)} - T_{A(MAX)}}{P_D}$$

$$\theta_{JA} = \frac{(150 - 40)}{1.8}$$

$$\theta_{JA} = 61^\circ C/W$$

3. Select a drain-source voltage, V(DS), rating greater than the maximum input voltage. A 12V device will be adequate in this example.

4. Select a device that has at least 50% higher drain current (ID) rating than the desired charge current I(REG).

5. Verify that the available drive is large enough to supply the desired charge current.

$$V(GS)=(VD+V(CS)+VOL(CC)) - VI(min)$$

$$V(GS)=(0.4+0.2+1)$$

$$V(GS)=2.9$$

Where V(GS) is the gate-to-source voltage, VD is the forward voltage drop across the reverse-blocking diode.(if one is used), and VCS is the voltage drop across the current sense resistor, and VOL(CC) is the CC pin output low voltage specification for the FS3871.

Select a MOSFET with gate threshold voltage, V(GStH),rating less than the calculated V(GS).

17. Package Outline

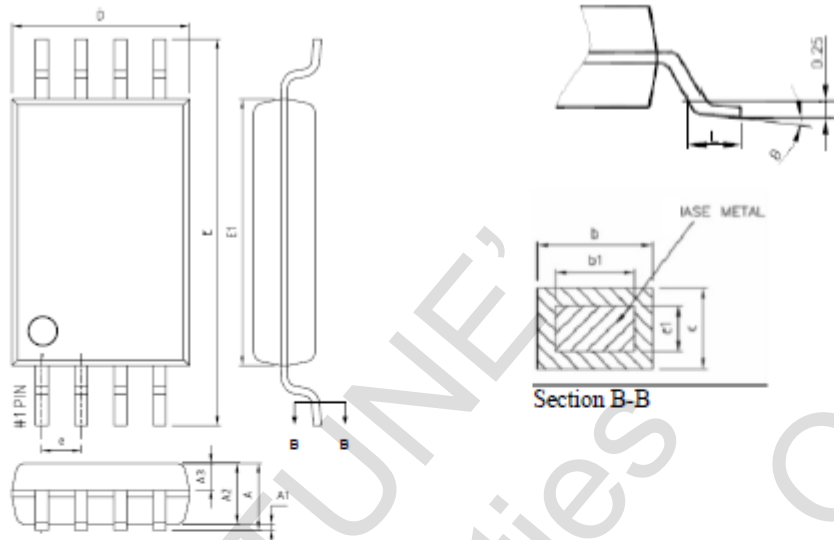

Unit: mm

Symbol	Min.	TYP.	Max.
A	-	-	1.2
A1	0.05	-	0.15
A2	0.8	1	1.05
b	0.19	-	0.3
b1	0.19	0.22	0.25
c	0.09	-	0.2
c1	0.09	0.13	0.16
D	2.9	3	3.1
E	6.4 BSC		
E1	4.3	4.4	4.5
e	0.65 BSC		
L	0.45	0.6	0.75
θ	0°	-	8°

Note

1. Refer to JEDEC MO-153 F
2. All dimensions do not include mold flash, gate burrs or protrusions

Revise History

Version	Date	Page	Description
1.0	2006/07/01	-	New release
1.1	2006/11/09	All	Revise datasheet format
1.2	2007/03/21	4 5 7 14	Revise Ordering Information to FS3871D/FS3871E Revise Operating free-air temperature range from -20~70°C to -10~70°C Revise IIB max current to 2uA Add Revise History
1.3	2010/02/10	4	Revise Ordering Information to FS3871D/FS3871E-G
1.4	2011/12/26	3 7 12	Revise TSSOP-8/MSOP-8 Green Package Revise MAX_V(SNS)L 130mV Revise Package Outline
1.5	2014/05/22	2	Revise company address
1.6	2024/11/26	3,4 6 7 10	Remove MSOP-8 Package Information Revise Figure 1. Add Figure 2 and Note. Revise Figure no.2 to no. 3. Revise Figure no.3 to no. 4.